



COMBiLiFT

THE Solution to your Poultry Collection Problems



BENEFITS:

- Small Turning Radius
- Operates Indoor And Outdoor
- Reduced Maintenance Costs
- No Mechanical Brakes To Adjust Or Replace
- Visibility-Offset Driving Position Gives Excellent View for Poultry Cage positioning



FEATURES:

- 3 Wheel Manoeuvrability
- All Wheel Hydrostatic Drive
- 30° Fork Rotation - Each Way
- 3 Stage Mast With Full - Free Lift
- Large Tractor Grip Tyres
- Diff-Lock Feature
- Deep Suspension Seat
- Back Up Alarm
- 150mm Mast Side Shift
- Pivot Forks

COMBi - RT
Poultry

www.COMBiLiFT.com



SPECIFICATIONS

COMBi - RT

DESCRIPTION	STD
Capacity	1250Kgs @1200mm
Unladen Weight	4400Kgs
Max. Ground Speed	14 km/h
Gradeability	40%
Kubota Water Cooled Diesel Engine	44kW (59Hp)
Electrics	12 Volt
Triplex Mast Lift Height	3150mm
Pivot Fork Section	50 x 125 x 1830mm
Slew Bearing Fork Rotator	30° Each Way
Pneumatic Tractor Grip Tires	ø 910mm width 290mm
Diesel Tank Capacity	85 litres
Hydraulic Tank Capacity	75 litres
3 Wheel Hydrostatic Drive	
3 Wheel Hydrostatic Braking	
Conforms to ANSI B56.6 Safety Standard for Rough Terrain Forklift Trucks	

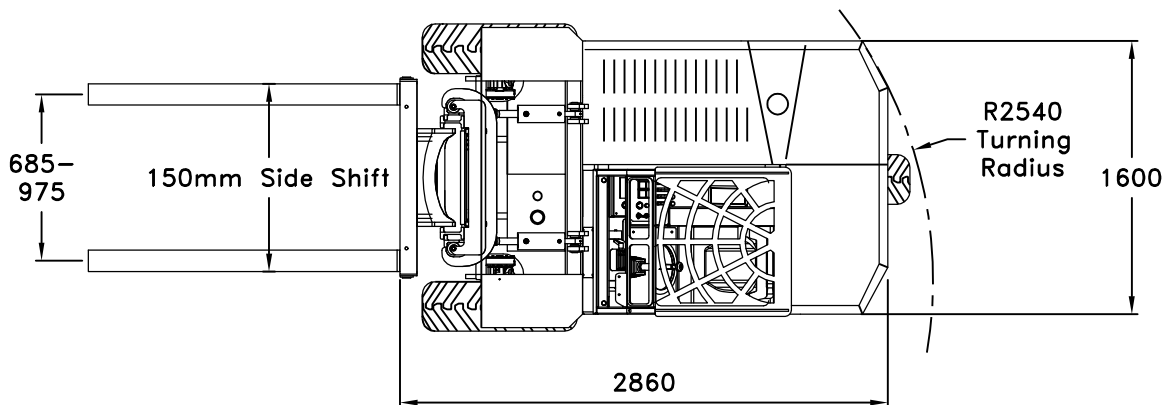
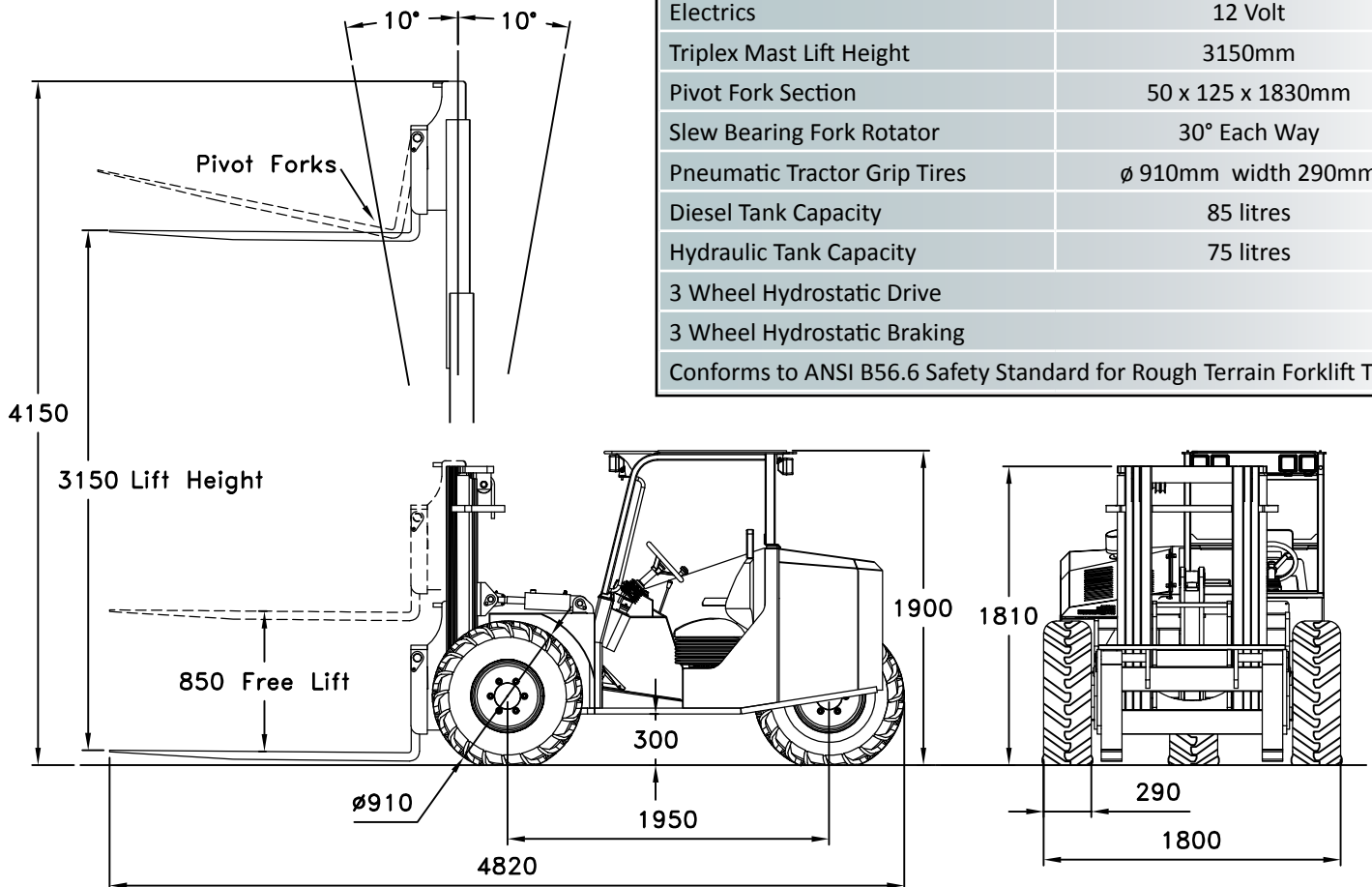

Distributed by

COMBiLiFT HQ

Gallinagh, Co Monaghan, IRELAND

Tel: +353 47 80500 Fax: +353 47 80501

E: info@combilift.com

www.COMBiLiFT.com